

VMF

 | Vibro®
Membrane
Filtration

Vibro-Lab3500

Benchtop Ultra- & Microfiltration

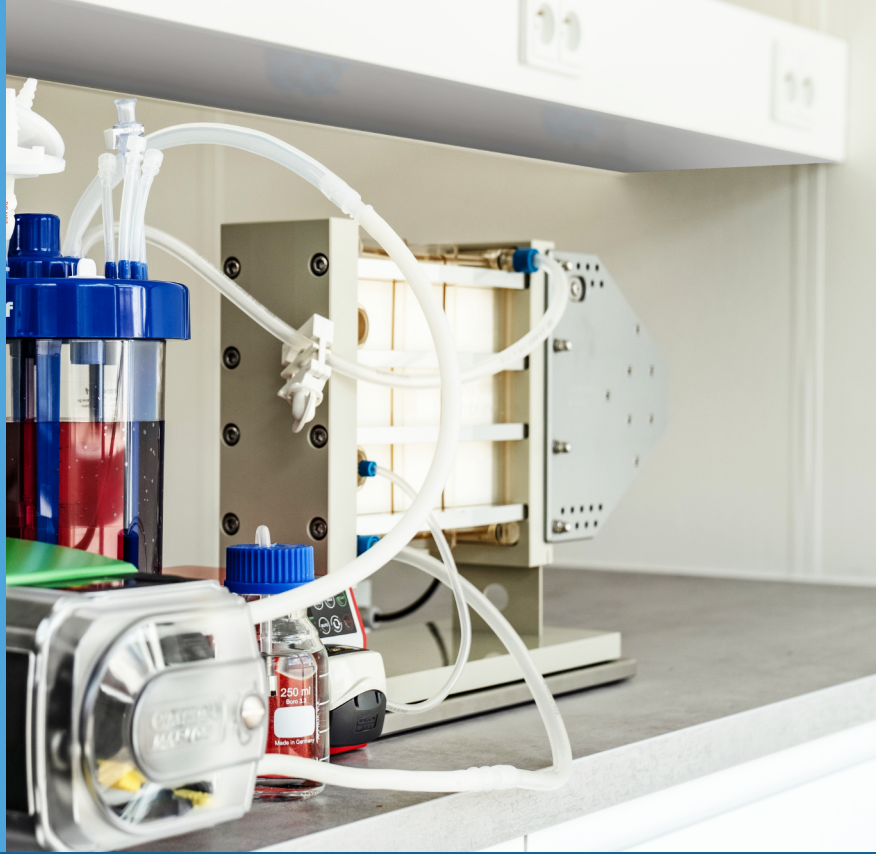

From setup to validation — simple, reliable, and fully supported.

Vibro-Lab3500

From lab to production

The Vibro-Lab3500 is the ideal system for advanced process development and scale-up, ensuring a seamless, linearly scalable transition from laboratory to industrial production.

Superior yield. Gentle processing.

The unique process control enables a low, uniform and controllable TMP, delivering superior recovery and high transmission of target molecules, where the gentle product handling makes it possible to reach very high concentrations and viscosities without compromising product quality.

Vibro®
Cartridge

Vibro®
Drive

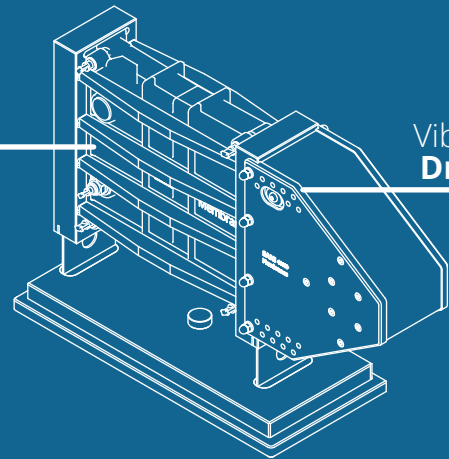

Ideal feed volume
2 L - 100 L



Configurable membrane
From 1 kDa **UF** to 1.2 μ m **MF**



Membrane area
3500 cm²

SANI

Membranes

Curious? Let's connect.



Michael Juul Jensen

Global Sales and Process Tech Manager

+45 5116 9818

mij@sanimembranes.com



Adam Poulsen

Pharma Key Account Manager

+45 5376 1497

apo@sanimembranes.com



LinkedIn

Vibro-Lab3500

Benchtop Ultra- & Microfiltration

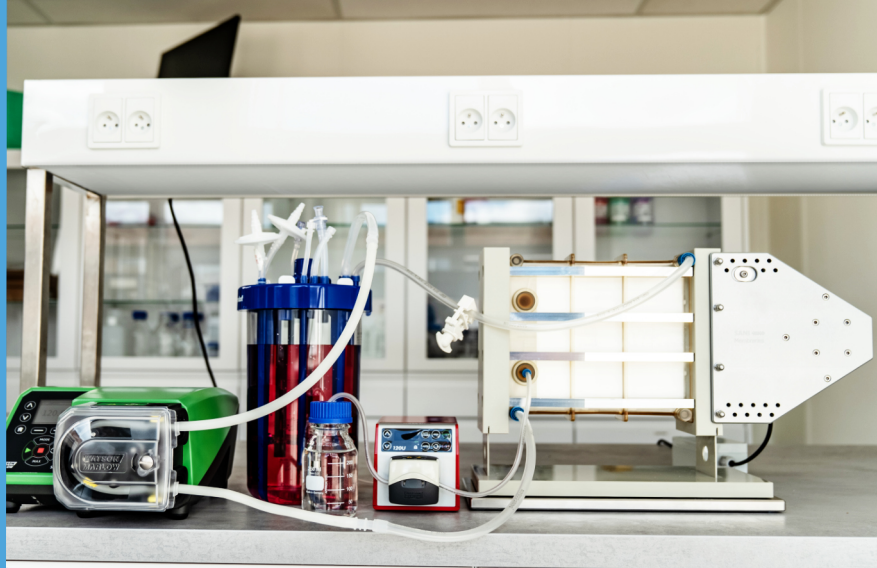

Specifications

Vibro-Lab3500 Drive

Mechanical specifications

Weight	12.7 kg + damper steel base 8.4 kg
Power consumption	40 W
Noise Level	< 60 dBA

Vibro® Lab3500 Cartridge

Mechanical specifications

Membrane area	3500 cm ²
Internal retentate volume	Ca. 500 mL
Internal permeate volume	170 mL
Drainable	Yes
Media contact materials	Polypropylene, EPDM, Stainless steel., food grade biopolymer, polyurethane.

Operational limitations

Operating pressure	0 -3 bar(g) (temp. dependent)
pH range	1 - 13 (membrane dependent)
Temperature range	5 - 55 °C
Viscosity range	1 - 1000 cP

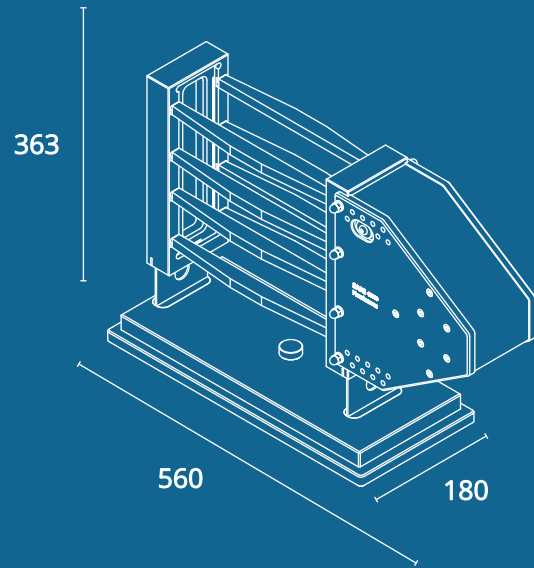

Retentate port
8 mm(OD) Push-In

Permeate port
6 mm(OD) Push-In

Feed port
8 mm(OD) Push-In

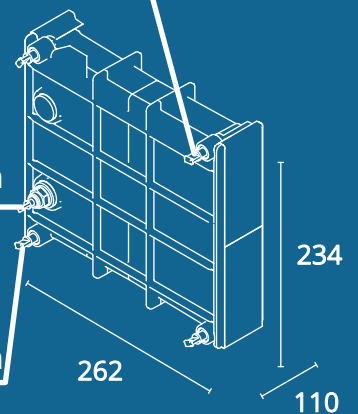

SANI 
Membranes

Curious? Let's connect.



Michael Juul Jensen

Global Sales and Process Tech Manager

+45 5116 9818

mij@sanimembranes.com



Adam Poulsen

Pharma Key Account Manager

+45 5376 1497

apo@sanimembranes.com



LinkedIn